

EL Series UV Lamps

Instruction Manual



UVP, LLC
2066 W 11th Street, Upland, CA 91786
Tel: (800) 452-6788 / (909) 946-3197
Fax: (909) 946-3597

Ultra-Violet Products Ltd.
Unit 1, Trinity Hall Farm Estate,
Nuffield Road Cambridge CB4 1TG UK
Tel: +44(0)1223-420022 / Fax: +44(0)1223-420561

Web site: www.uvp.com

81-0117-01 Rev D

Introduction

The EL Series Ultraviolet Lamps offer a uniform and intense source of ultraviolet light (radiation). The lamps emit one of three UV wavelengths or white light in four watt, six watt and eight watt configurations for exposure/illumination of materials. All EL Series Lamps can be used with the universal J138 Lamp Stand. The four watt models can be used with C-10E Cabinet for viewing materials in a darkroom environment. Eight watt lamps can be used with the C-65 Cabinet.

NOTE: Though the manual refers to the midrange UV waveband as 302nm, others refer to this region as 300nm or 312nm. The spectral output of all these regions is the same.

CAUTION: Shortwave and midrange UV radiation will cause damage to unprotected eyes and skin. Before operating any unit, be sure all personnel in the area are properly protected. UV Blocking Eyewear should be worn as well. UVP has a complete line of UV Blocking Eyewear: Spectacles, Goggles and Faceshield designed for this purpose.

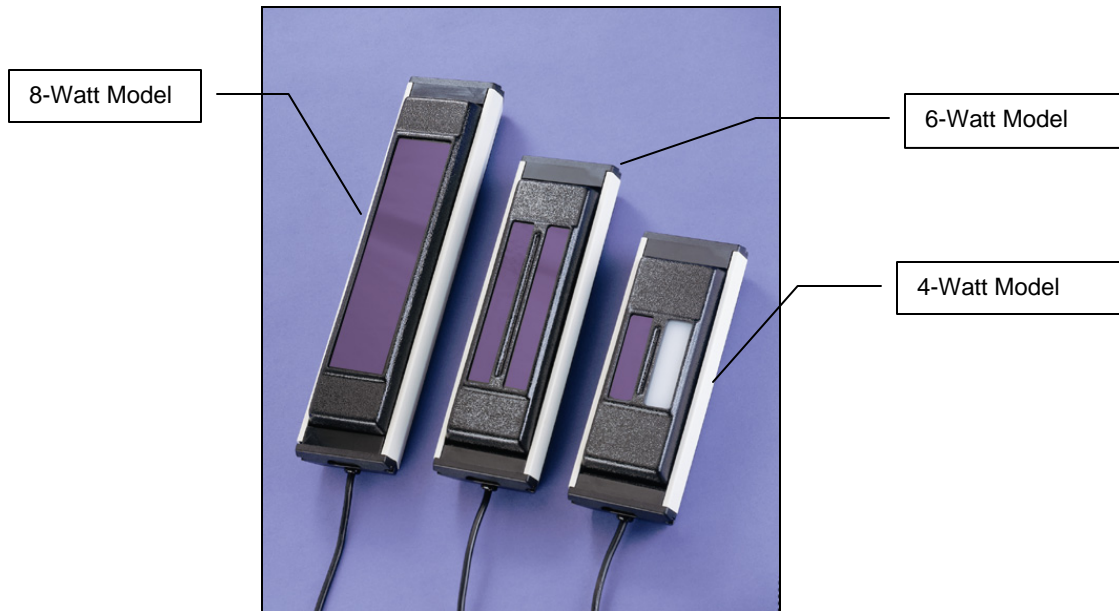

Specifications

EL Lamps - Four Watt Models

Dimensions: 9.8"L x 2.5"H x 3.8"W (249 x 64 x 97 mm)

<i>Model</i>	<i>Part Number</i>	<i>Volt/Hz/Amp</i>	<i>Wavelength</i>
UVS-14	95-0266-01	115/60/0.16	254nm/White (one tube each)
	95-0266-02	230/50/0.16	
	95-0266-03	100/50-60/0.16	
UVL-14	95-0264-01	115/60/0.16	365nm/White (one tube each)
	95-0264-02	230/50/0.16	

	95-0264-03	100/50-60/0.16	
UVS-24	95-0269-01	115/60/0.32	254nm (two tubes)
	95-0269-02	230/50/0.32	
	95-0269-03	100/50-60/0.32	
UVL-24	95-0267-01	115/60/0.32	365nm (two tubes)
	95-0267-02	230/50/0.32	
	95-0267-03	100/50-60/0.32	
UVLS-24	95-0271-01	115/60/0.16	365/254nm (one tube each)
	95-0271-02	230/50/0.16	
	95-0271-03	100/50-60/0.16	

EL Lamps - Six Watt Models

Dimensions: 11.9"L x 2.5"H x 3.8"W (302 x 64 x 97 mm)

<i>Model</i>	<i>Part Number</i>	<i>Volt/Hz/Amp</i>	<i>Wavelength</i>
UVS-16	95-0274-01	115/60/0.16	254nm/White (one tube each)
	95-0274-02	230/50/0.16	
	95-0274-03	100/50-60/0.16	
UVL-16	95-0272-01	115/60/0.16	365nm/White (one tube each)
	95-0272-02	230/50/0.16	
	95-0272-03	100/50-60/0.16	
UVM-16	95-0273-01	115/60/0.16	302nm/White (one tube each)
	95-0273-02	230/50/0.16	
	95-0273-03	100/50-60/0.16	
UVS-26	95-0277-01	115/60/0.32	254nm (two tubes)
	95-0277-02	230/50/0.32	
	95-0277-03	100/50-60/0.32	
UVL-26	95-0275-01	115/60/0.32	365nm (two tubes)
	95-0275-02	230/50/0.32	
	95-0275-03	100/50-60/0.32	
UVM-26	95-0276-01	115/60/0.16	302nm/White (two tubes)
	95-0275-02	230/50/0.16	
	95-0275-03	100/50-60/0.16	
UVLS-26	95-0279-01	115/60/0.16	365/254nm (one tube each)
	95-0279-02	230/50/0.16	
	95-0279-03	100/50-60/0.16	
UVLM-26	95-0278-01	115/60/0.16	365/302nm (one tube each)
	95-0278-02	230/50/0.16	
	95-0278-03	100/50-60/0.16	

EL Lamps - Eight Watt Models

Dimensions: 14.9"L x 2.5"H x 3.8"W (376 x 64 x 97 mm)

<i>Model</i>	<i>Part Number</i>	<i>Volt/Hz/Amp</i>	<i>Wavelength</i>
UVS-18	95-0200-01	115/60/0.16	254nm/White (one tube each)

	95-0200-02	230/50/0.16	
	95-0200-03	100/50-60/0.16	
UVL-18	95-0198-01	115/60/0.16	365nm/White (one tube each)
	95-0198-02	230/50/0.16	
	95-0198-03	100/50-60/0.16	
UVM-18	95-0199-01	115/60/0.16	302nm/White (one tube each)
	95-0199-02	230/50/0.16	
	95-0199-03	100/50-60/0.16	
UVS-28	95-0249-01	115/60/0.32	254nm (two tubes)
	95-0249-02	230/50/0.32	
	95-0249-03	100/50-60/0.32	
UVL-28	95-0248-01	115/60/0.32	365nm (two tubes)
	95-0248-02	230/50/0.32	
	95-0248-03	100/50-60/0.32	
UVM-28	95-0250-01	115/60/0.32	302nm (two tubes)
	95-0250-02	230/50/0.32	
	95-0250-03	100/50-60/0.32	
UVLS-28	95-0201-01	115/60/0.16	365/254nm (one tube each)
	95-0201-02	230/50/0.16	
	95-0201-03	100/50-60/0.16	
UVLM-28	95-0251-01	115/60/0.16	365/302nm (one tube each)
	95-0251-02	230/50/0.16	
	95-0251-03	100/50-60/0.16	
UVLMS-38	95-0252-01	115/60/0.16	365/302/254nm (one tube each)
	95-0252-02	230/50/0.16	
	95-0252-03	100/50-60/0.16	

Operation

Safety Precautions

Shortwave and midrange UV radiation will cause damage to unprotected eyes and skin. Before operating any unit, be sure all personnel in the area are properly protected. UV Blocking Eyewear should be worn as well.

Using the Lamp

- Plug power cord into a properly grounded electrical outlet. The proper voltage of the lamp is found on the product information label.
- The power switch is conveniently located on top of the unit to turn the lamp on or off.
- For models with multiple wavelengths the switch allows selection of wavelength or to shut the unit off.
- Each lamp comes with two UV tube or one UV and one white light tube. The UVLMS-38 is equipped with three tubes. Models with two tubes of the same wavelength operate with both tubes on at the same time. Other models operate with only a single tube a time.

Service Procedures

Return Procedure

A **Returned Goods Authorization (RGA)** number must be obtained from UVP Customer Service before returning any product to UVP.

Cleaning and Care

Clean unit surface with a damp soft cloth or sponge. Never use abrasive cleaners (can damage the UV filter surface).

Replacing Tubes

- Disconnect the lamp from the electrical supply before replacing tubes.
- Remove the two Phillips Head screws located in the end cap.
- Grasp the extruded housing and slide the chassis and filter out together away from the switch.
- Disconnect the interior Molex Connector (Fig. 1) and slide the chassis and filter out from the housing completely.

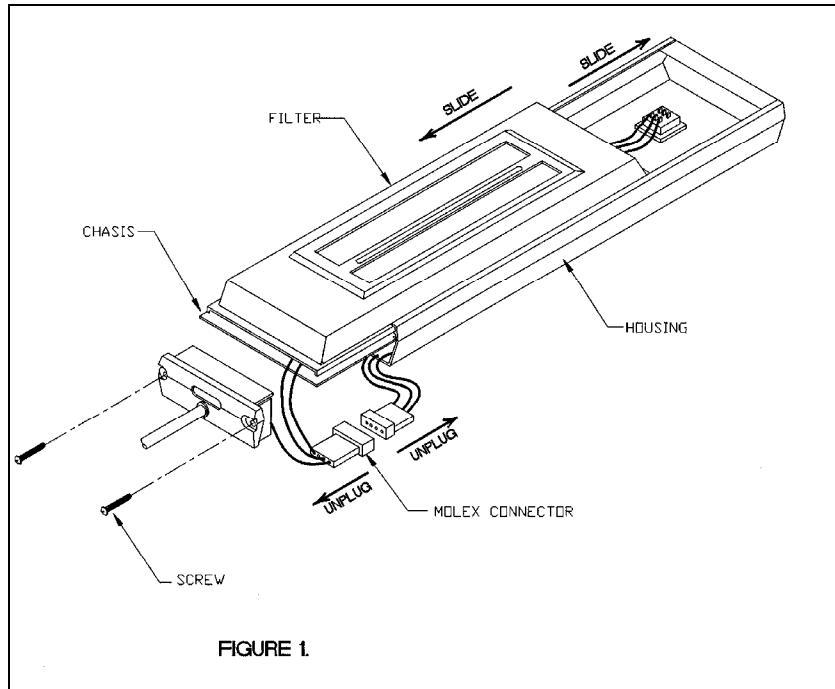

- Once out of the extrusion, the chassis and filter will come apart.

- Carefully grasp the tube ends and twist one quarter turn until it works free (Fig. 2)

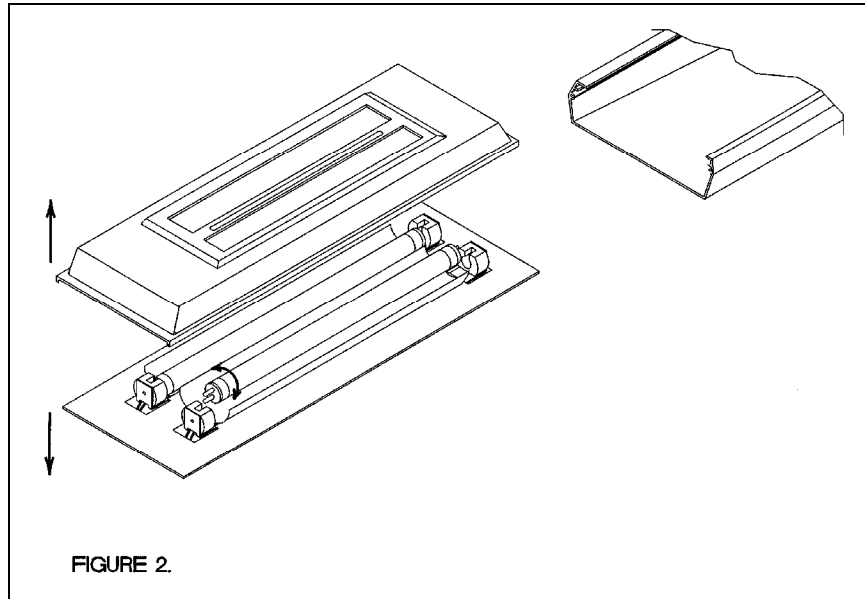

- Insert the new tube, giving it a twist to lock in place.
- Reassemble the lamp. Do not pinch wires during assembly.

Replacement Parts/Accessories

For replacement parts or components not shown here, please call UVP Customer Service or place of purchase. Please have the lamp model available when you call.

<u>Replacement Part Description</u>	<u>Part Number</u>
Tube, 4 watt, 365nm	34-0005-01
Tube, 4 watt, 254nm	34-0066-01
Tube, 4 watt, white	34-0003-01
Tube, 6 watt, 365nm	34-0034-01
Tube, 6 watt, 254nm	34-0015-01
Tube, 6 watt, 302nm	34-0044-01
Tube, 6 watt, white	34-0063-01
Tube, 8 Watt, 365nm	34-0006-01
Tube, 8 Watt, 254nm	34-0007-01
Tube, 8 Watt, 302nm	34-0042-01
Tube, 8 Watt, white	34-0056-01
<u>Accessories Description</u>	<u>Part Number</u>
Spectacles, UV Blocking	98-0002-01
Goggles, UV Blocking	98-0002-02
Faceshield, UV Blocking	98-0002-04



J-138 Lamp Stand

C-65 Cabinet (for 8-watt lamps)

C-10E Cabinet (for 4-watt lamps)

18-0063-01

95-0257-01

95-0072-08

Technical Support

UVP offers technical support for all of its products. If you have any questions about the product's use or operation, please contact UVP's offices at the following locations.

If you are in North America, South America, East Asia or Australia:

- **Call (800) 452-6788 or (909) 946-3197 Customer Service** regular business days, between 7 am and 5 pm PST
- **E-Mail:** info@uvp.com
- **Fax Customer Service:** (909) 946-3597
- **Write to:** UVP, LLC
2066 W. 11th Street
Upland, CA 91786 USA

If you are in Europe, Africa, the Middle East, Western Asia:

- **Call +44(0) 1223-420022 Customer** regular business days, between 9 am and 5:30 pm
- **E-Mail:** uvp@uvp.co.uk
- **Fax Customer Service:** +44(0)1223-420561
- **Write to:** Ultra-Violet Products Ltd.
Unit 1, Trinity Hall Farm Estate, Nuffield Rd
Cambridge CB4 1TG UK

Note: A **Returned Goods Authorization (RGA) number** must be obtained from UVP Customer Service before returning any product.

Warranty

LIMITED WARRANTY: UVP's quality instruments are guaranteed to be free of defects in materials, workmanship, and manufacture for one (1) year from date of purchase. Transilluminators are similarly warranted for two (2) years from the date of purchase. Consumable and disposable products, including, but not limited to lamps or light tubes, filters, or rechargeable batteries are guaranteed to be free from defects in manufacture and materials for ninety (90) days from date of purchase.

If equipment failure or malfunction occurs during the warranty period, UVP shall examine the inoperative equipment and have the option of repairing or replacing any part(s) which, in the sole and absolute discretion of UVP, were originally defective or became so under conditions of normal usage and service. No warranty shall apply to any instrument, or part thereof, that has been subject to accident, negligence, alteration, abuse or misuse by the end user. Moreover, UVP makes no warranties whatsoever with respect to parts not supplied by UVP

or that have been installed, used and/or serviced other than in strict compliance with the instructions appearing in this installation and instruction manual. In no event shall UVP be responsible to the end-user for any incidental or consequential damages, whether foreseeable or not, including but not limited to property damage, inability to use equipment, loss of business, loss of profits, or inconvenience arising out of or connected with the use of instruments produced by UVP. Nor is UVP liable or responsible for any personal injuries occurring as a result of the use, misuse, installation and/or servicing of equipment. Representations and warranties made by any person, including dealers and representatives of UVP which are inconsistent or in conflict with the terms of this warranty (including but not limited to the limitations of the liability of UVP as set forth above), shall not be binding upon UVP unless reduced to writing and approved by an expressly authorized representative of UVP.

THIS WARRANTY IS EXPRESSED IN LIEU OF ALL OTHER WARRANTIES, EXPRESSED OR IMPLIED, INCLUDING THE IMPLIED WARRANTIES OF MERCHANTABILITY AND FITNESS FOR A PARTICULAR PURPOSE AND OF ALL OTHER OBLIGATIONS OR LIABILITIES ON UVP'S PART AND UVP NEITHER ASSUMES NOR AUTHORIZES ANY PERSON TO ASSUME FOR UVP ANY OTHER LIABILITIES IN CONNECTION WITH THE SALE OF THE SAID PRODUCTS.